



STAMPAGGIO METALLI A FREDDO
COLD METAL FORMING

Fascette a cavallotto U-bolt clamps

modello/model

G10

Fascetta a cavallotto
modello simile "Ford" rinforzata
*Reinforced U-bolt clamp
model similar to "Ford"*

materiale/material

Acciaio
Stell

trattamento/treatment

Zincatura CrIII - tipo II
Zinc-plating CrIII - II

Ø nominale/nominal Ø

da 35 a 125
from 35 to 125

vite/screw

M10

forza serraggio/torque

max 30 Nm

Normativa/norm

Conforme 2000/53/CE+RoHS
2000/53/EC+RoHS compliant



COD.	Pack*	ØD ¹	A	B	C	S	COD.	Pack*	ØD ¹	A	B	C	S
G10 035 Y	A1/A2/S3	35	29,5	79	23,5	2	G10 069 Y	A1/A2/S3	69	45	108,5	24,5	2,5
G10 038 Y	A1/A2/S3	38	30	80	23,5	2	G10 072 Y	A1/A2/S3	72	49	109,5	24,5	2,5
G10 040 Y	A1/A2/S3	40	32,5	81	23,5	2	G10 076 Y	A1/A2/S3	76	42,5	119,5	22	2,5
G10 043 Y	A1/A2/S3	43	37,5	81,5	22	2	G10 080 Y	A1/A2/S3	80	45,5	121	22,5	2,5
G10 045 Y	A1/A2/S3	45	36	83,5	21,5	2	G10 086 Y	A1/A2/S3	86	51	123	21,5	2,5
G10 048 Y	A1/A2/S3	48	37,5	87,5	22,5	2	G10 089 Y	A1/A2/S3	89	49	132,5	22,5	2,5
G10 051 Y	A1/A2/S3	51	39	90	22	2	G10 092 Y	A1/A2/S3	92	54	134,5	21,5	2,5
G10 054 Y	A1/A2/S3	54	39,5	93	21,5	2	G10 098 Y	A1/A2/S3	98	57	136,5	21,5	2,5
G10 057 Y	A1/A2/S3	57	41,5	93,5	24	2	G10 106 Y	A1/A2/S3	106	57,5	153	25	2,5
G10 060 Y	A1/A2/S3	60	41,5	93,5	22	2	G10 110 Y	A1/A2/S3	110	60	154,5	23,5	2,5
G10 063 Y	A1/A2/S3	63	41,5	106,5	23	2,5	G10 118 Y	A1/A2/S3	118	69	157	23,5	2,5
G10 066 Y	A1/A2/S3	66	43	107,5	22,5	2,5	G10 125 Y	A1/A2/S3	125	73,5	159,5	24	2,5

*Conf./Pack A1 = Assemblata in Sacchi da 100pz (dal Ø63 da 50pz) / Assembled in bags of 100 pcs (from Ø63 of 50pcs)
A2 = Assemblata in Scatola da 10pz (dal Ø63 da 5pz) / Assembled in Boxes of 10 pcs (from Ø63 of 50pcs)
S3 = Smontata in Busta da 1pz / Non assembled in Single Bag

¹ ØD È il diametro nominale da stringere / It is nominal diameter to tighten

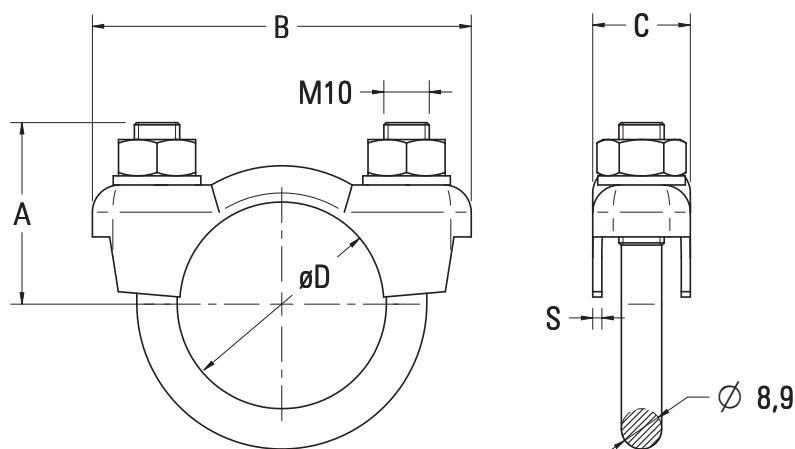

misure in/measures in: mm

B e B di Bazzani Francesca e Bazzani Filippo snc / Via F. Borromini 1, Loc. Sambuca 50028 Tavarnelle Val di Pesa (FI) Italia
Tel +39 055 80.71.591 / Fax +39 055 80.71.259 / E-mail: info@bebweb.it / Web-site: www.bebweb.it
Organizzazione con sistema di gestione certificato UNI EN ISO 9001:2000 / Organization with certified system of management UNI EN ISO 9001:2000

© B e B di Bazzani Francesca e Bazzani Filippo snc / Le informazioni riportate nel presente documento sono a titolo indicativo. L'azienda si riserva il diritto di apportare modifiche senza preavviso. The information contained in this document is purely indicative. The company reserves the right to introduce changes without prior notice.

G10 - Rev. A

